brenda l. speer llc
 ATTORNEY AT LAW

LEGAL ISSUES IN THE ARTS

- An Overview -

© 2007 Brenda L. Speer

brenda l. speer, llc | 719.381.1708 | fax: 719.466.8098
 brenda@blspeer.com | www.blspeer.com
 2 NORTH CASCADE AVENUE, SUITE 1100, COLORADO SPRINGS, CO 80903

protecting the technological and creative arts

brenda l. speer llc
 ATTORNEY AT LAW

DISCLAIMER!

- This may be boring
- You may not learn anything
- If you learn something, it'll probably be enough to make you dangerous
- This is **NOT** legal advice

protecting the technological and creative arts

brenda l. speer llc
 ATTORNEY AT LAW

IDEAS AND CONCEPTS

- Are **not protectable** in and of themselves
- Legal protection extends to the **tangible expression** of ideas and concepts
- This tangible expression is known as **Intellectual Property** ("IP")

protecting the technological and creative arts

brenda l. speer llc
 ATTORNEY AT LAW

INTELLECTUAL PROPERTY

- **What?**
 - **Tangible Expression** of creative human endeavor
 - **Protected by**
 - **Patents**
 - **Trademarks**
 - **Copyrights**
 - **Trade Secrets**

protecting the technological and creative arts

brenda l. speer llc
 ATTORNEY AT LAW

Intellectual Property...

- **Transportation Analogy**
 - Cars drive on land 
 - Ships sail on water 
 - Planes fly in air 
 - Hydroplanes travel on water and in air 

protecting the technological and creative arts

brenda l. speer llc
 ATTORNEY AT LAW

Intellectual Property...

- **Patents** → Inventions or Discoveries
- **Trademarks** → Indicators of Source
- **Copyrights** → Original Works
- **Trade Secrets** → Confidential Information

protecting the technological and creative arts

Intellectual Property...

- **Rights?**
 - **Limited term monopoly** in exchange for promotion of the useful arts and sciences

protecting the technological and creative arts

Intellectual Property...

- **How Long?**
 - Until becomes **Public Domain**
 - Available for all to use
 - **Caveat:**
 - Public Availability \neq Public Domain

protecting the technological and creative arts

PATENTS

- **What?**
 - **Inventions or Discoveries**
 - Three Types
 - **Utility**
 - **Design**
 - **Plant**

protecting the technological and creative arts

Utility Patent

Any **new, useful** and **nonobvious**

- **Process** (*making a mosaic collage*)
- **Machine** (*giclée print maker*)
- **Manufacture** (*paint tube*)
- **Composition of Matter** (*acrylic paint*)
- **Improvement thereof** (*easel with hand rest*)

protecting the technological and creative arts

United States Patent

Patent No. US 6,560,059 B1

Date of Patent: May 26, 2003

INVENTOR: JAMES R. HARRIS, JR.

ATTORNEY: BRANDO L. SPEAR, JR.

ABSTRACT: A portable spotlight is disclosed. The spotlight includes a housing, a lens, and a reflector. The housing is configured to be mounted on a stand. The lens is positioned to project light from the reflector. The reflector is configured to reflect light from the lens. The housing is configured to be rotated about a vertical axis. The lens is configured to be rotated about a horizontal axis. The reflector is configured to be rotated about a horizontal axis. The housing is configured to be rotated about a vertical axis. The lens is configured to be rotated about a horizontal axis. The reflector is configured to be rotated about a horizontal axis.

FIG. 1

protecting the technological and creative arts

Design Patent

Any **new, original** and **ornamental design** for an article of manufacture
(portable spotlight)

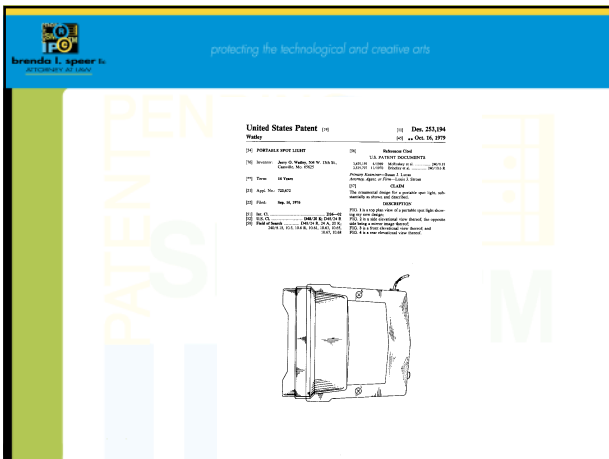

protecting the technological and creative arts

Patents...

- **Rights?**
 - **Exclusive** right to
 - **Make**
 - **Use** and
 - **Sell**

protecting the technological and creative arts

Patents...

- **Where?**
 - **National Border**

protecting the technological and creative arts

Patents...

- **How Long?**
 - **Utility:** **20** years from filing date
 - **Design:** **14** years from grant date

protecting the technological and creative arts

Patents...

- **Public Domain?**
 - **Expiration** of grant

protecting the technological and creative arts

Patents...

- **Marking?**
 - U.S. Patent No. 6,565,059 (**utility**)
 - U.S. Patent No. D253,194 (**design**)
 - U.S. Pat. Pend. (**pending application**)

protecting the technological and creative arts

Patents...

- **Acquisition of Rights?**
 - Upon **grant**
 - US **Patent & Trademark Office**
 - **Registration required**

protecting the technological and creative arts

TRADEMARKS

- **What?**
 - **Trademark:** Indicator of source or origin of a good or service
 - Trademarks may consist of:

protecting the technological and creative arts

Words

Coca-Cola



protecting the technological and creative arts

Phrases



protecting the technological and creative arts

Designs



protecting the technological and creative arts

Combinations Thereof



protecting the technological and creative arts

Scents, Sounds & Colors

- **Scent**
 - Smead
 - Vanilla and others for office supplies
- **Sound**
 - NBC
 - Chimes for broadcasting services
- **Color**
 - Owens Corning
 - Pink for insulation

protecting the technological and creative arts

Trademarks

- **Proper Format**
 - **Always** use as an **ADJECTIVE**
 - Trademark brand noun
 - **Big Chief**[®] brand writing tablet
 - **Not** as a **noun**
 - Please make a Xerox of this document.
 - **Not** as a **verb**
 - Let's go rollerblading in the park.

protecting the technological and creative arts

Trademarks...

- **Art Applications**
 - **Goods** (pottery)
 - **Services** (ceramic classes)
 - **Characters** (Mickey Mouse)

protecting the technological and creative arts

Trademarks...

- **What?**
 - **Exclusive right** to use trademark with **particular** goods and services.

protecting the technological and creative arts

Trademarks...

- **Where?**
 - **Common Law Usage:** Demonstrated territory
 - **State Registration:** State border
 - **Federal Registration:** National border

protecting the technological and creative arts

Trademarks...

- **How Long?**
 - **Common Law Usage:** As long as continuously used
 - **State Registration:** Usually 10 years (subject to renewal and continuous use)
 - **Federal Registration:** 10 years (subject to renewal and continuous use)

protecting the technological and creative arts

Trademarks...

- **Public Domain?**
 - *No longer* in *continual use*
 - At least 3 years of non-use

protecting the technological and creative arts

Trademarks...

- **Marking?**
 - MARK® (*Federal* Registration)
 - MARK™ (*State* Registration and/or *Common Law* Usage)

protecting the technological and creative arts

Trademarks...

- **Acquisition of Rights?**
 - Upon *use* of the mark in *commerce*
 - US Patent & Trademark Office
 - Secretary of State

protecting the technological and creative arts

Trademarks...

- **Acquisition of Rights...**
 - *Registration not required, but*
 - Proof of *rights*
 - Proof of *ownership*
 - Public *record*



protecting the technological and creative arts

COPYRIGHTS

- **What?**
 - *Original works of authorship* fixed in any *tangible* medium of expression

protecting the technological and creative arts

Copyrights...

- **Works?**
 - *Literary* works 
 - *Musical* works  (including any accompanying words)
 - *Dramatic* works  (including any accompanying music)

protecting the technological and creative arts

Copyrights...

- **Works...**
 - **Pictorial, Graphic**    
 - **Motion Pictures**  
 - **Sound Recordings**  

protecting the technological and creative arts

Copyrights...

- **Rights?**
 - Exclusive **RightS**
 - **Reproduce** the work
 - **Prepare** derivative works
 - **Distribute** copies
 - **Perform** publicly
 - **Display** publicly

protecting the technological and creative arts

Copyrights...

- **Where?**
 - **National** Border
 - **International** Reciprocity

protecting the technological and creative arts

Copyrights...

- **How Long?**
 - **Individual Work:** Life of author plus 70 years
 - **Joint Work:** Life of last-surviving author plus 70 years
 - **Anonymous Work, Pseudonymous Work, Work for Hire:** Earlier of
 - 95 years from publication
 - 120 years from creation

protecting the technological and creative arts

Copyrights...

- **Public Domain?**
 - **Expiration** of term

protecting the technological and creative arts

Copyrights...

- **Marking?**
 - **Copyright**
 - Symbol (©)
 - Word (Copyright)
 - Abbreviation (Copr.)
 - **Year** of Creation or Publication
 - **Author** Name

protecting the technological and creative arts
 brenda l. spear llc
 ATTORNEY AT LAW

Copyrights...

- **Marking...**
 - **Visually Perceptible Copies**
 - © 2007 Author Name
 - Copyright 2007 Author Name
 - Copr. 2007 Author Name

protecting the technological and creative arts
 brenda l. spear llc
 ATTORNEY AT LAW

Copyrights...

- **Marking...**
 - **Sound Recordings**
 - © 2007 Author Name

protecting the technological and creative arts
 brenda l. spear llc
 ATTORNEY AT LAW

Copyrights...

- **Acquisition of Rights?**
 - Upon **creation**
 - US **Copyright Office**

protecting the technological and creative arts
 brenda l. spear llc
 ATTORNEY AT LAW

Copyrights...

- **Acquisition of Rights...**
 - **Registration** *not* required, *but* provides
 - Proof of **ownership**
 - Public **record**
 - Required to bring **suit**
 - File within 3 months of *Publication*
 - Damages
 - Attorneys Fees

protecting the technological and creative arts
 brenda l. spear llc
 ATTORNEY AT LAW

Copyrights...

- **Infringement?**
 - **Legal Test**
 - **Access** to original work and
 - **Substantial similarity** to original work
 - **Myth**
 - Not infringement if change by X%

protecting the technological and creative arts
 brenda l. spear llc
 ATTORNEY AT LAW

Copyrights...

- **Infringement Exceptions?**
 - **Express Permission**
 - **Fair Use Defense**
 - *Purpose and character of use*
 - *Nature of the copyrighted work*
 - *Amount and substantiality*
 - *Effect on the potential market*

protecting the technological and creative arts

TRADE SECRETS

- **What?**
 - **Business information** that has
 - **Commercial value**
 - Provides an actual or potential **economic advantage** over others
 - Is **maintained in confidence**

protecting the technological and creative arts

Trade Secrets...

- **Rights?**
 - **Exclusive** right to **use**

protecting the technological and creative arts

Trade Secrets...

- **Where?**
 - **State by State**
 - Other areas of legal recognition

protecting the technological and creative arts

Trade Secrets...

- **How Long?**
 - As long as maintained in **confidence**



protecting the technological and creative arts

Trade Secrets...

- **Public Domain?**
 - **Disclosure**
 - By **anyone**
 - With or without fault

protecting the technological and creative arts

Trade Secrets...

- **Marking?**



protecting the technological and creative arts

Trade Secrets...

- Acquisition of Rights?
 - Upon *creation*
 - Not Registered
 - Contractual Right

protecting the technological and creative arts

CONTRACTS

- What?
 - *Grant of Rights* in property

protecting the technological and creative arts

Contracts...

- Rights?
 - *Own and use* for yourself
 - *Own and someone else uses*
 - License
 - *Sell and no ownership or use*
 - Work for Hire
 - Commissioned Work

protecting the technological and creative arts

Contracts...

- What?
 - *Licensing*
 - *Work for Hire*
 - *Commissioned Work*

protecting the technological and creative arts

Contracts...

- How?
 - *Contract before* you start the transaction
 - Seek professional *guidance*
 - *Provisions*
 - Who, what, when, where, why & how

protecting the technological and creative arts

Contracts...

- **Licensing?**
 - Parties
 - Property Rights
 - Term
 - Territory
 - Transferability
 - Exclusivity
 - Quantity
 - Quality
 - Royalty
 - Remedies
 - Other

protecting the technological and creative arts
brenda l. spear llc ATTORNEY AT LAW

Contracts...

- **Work for Hire?**
 - **What?**
 - Term defined by statute
 - **Who?**
 - Parties
 - Employer and Employee
 - Employment relationship
 - Commissioner and Commissionee
 - In *writing beforehand*

protecting the technological and creative arts
brenda l. spear llc ATTORNEY AT LAW

Contracts...

- **Works?**
 - *Contribution* to a Collective Work
 - Part of a *Motion Picture* or other *Audiovisual* Work
 - *Translation*
 - *Supplementary* Work
 - *Compilation*
 - *Instructional* Text
 - *Test*
 - *Answer* Material for a Test
 - *Atlas*

protecting the technological and creative arts
brenda l. spear llc ATTORNEY AT LAW

Contracts...

- **Commissioned Work?**
 - *May* or *may not* fit within definition
 - *May* or *may not* transfer ownership
 - Effective ownership transfer
 - In writing
 - Before work is done, preferably
 - *May* or *may not* waive visual art rights

protecting the technological and creative arts
brenda l. spear llc ATTORNEY AT LAW

VISUAL ART RIGHTS

- **What?**
 - Unique copyright protection (1990)
 - Also known as *Moral Rights*

protecting the technological and creative arts
brenda l. spear llc ATTORNEY AT LAW

Visual Art Rights...

- **Who?**
 - *Author* only
 - *Not Transferable*
 - *Waiver* of rights in writing
- **How Long?**
 - *Life* of author

protecting the technological and creative arts
brenda l. spear llc ATTORNEY AT LAW

Visual Art Rights...

- **Rights?**
 - *Attribution & Integrity*
 - *Claim authorship*

protecting the technological and creative arts

Visual Art Rights...

- **Claim authorship...**
 - **Prevent use of name**
 - Not the creator
 - Distortion, mutilation, modification of work prejudicial to honor or reputation
 - **Prevent abuse of work**
 - Distortion, mutilation, modification of work prejudicial to honor or reputation
 - Destruction (intentional or negligent)

protecting the technological and creative arts

Visual Art Rights...

- **Works?**
 - **Painting**
 - **Drawing**
 - **Print**
 - **Sculpture**
 - **Photograph**

protecting the technological and creative arts

Visual Art Rights...

- **Painting, Drawing or Print**
 - **Single copy**, or
 - **Limited edition**
 - ≤ 200 copies
 - Signed
 - Consecutively numbered

protecting the technological and creative arts

Visual Art Rights...

- **Sculpture**
 - **Multiple Cast**
 - **Carved**
 - **Fabricated**
- **Requirements**
 - ≤ 200 copies
 - **Signature** or identifying mark
 - Consecutively numbered

protecting the technological and creative arts

Visual Art Rights...

- **Photograph**
 - **Still image**
- **Requirements**
 - **Single copy**
 - produced for **exhibition** purposes only
 - Signed
 - **Limited edition**
 - ≤ 200 copies
 - **Signature** or identifying mark
 - Consecutively numbered

protecting the technological and creative arts

DESIGN COPYRIGHT

- **What?**
 - Unique copyright protection (1998)

protecting the technological and creative arts
brenda l. spear llc ATTORNEY AT LAW

Design Copyright...

- **What?**
 - *Original design* of a *useful article* which makes the article *attractive or distinctive in appearance* to the purchasing or using public

protecting the technological and creative arts
brenda l. spear llc ATTORNEY AT LAW

Design Copyright...

- **Rights?**
 - *Make, have made, or import*
 - *Sell* or *distribute*

protecting the technological and creative arts
brenda l. spear llc ATTORNEY AT LAW

Design Copyright...

- **Where?**
 - *United States*
- **How Long?**
 - *10 years* from publication

protecting the technological and creative arts
brenda l. spear llc ATTORNEY AT LAW

Design Copyright...

- **Marking?**
 - *Designator*
 - Symbol ("D" within a circle or *D*)
 - Words (Protected Design)
 - Abbreviation (Prot'd Des.)
 - *Year* of Protection
 - *Owner* Name

protecting the technological and creative arts
brenda l. spear llc ATTORNEY AT LAW

Design Copyright...

- **Acquisition of Rights?**
 - Upon *publication*, provided
 - *Registration* within *2* years
 - US *Copyright Office*
 - Trumped by design patent

protecting the technological and creative arts
brenda l. spear llc ATTORNEY AT LAW

QUESTIONS

- **ANSWERS**
 - The Answer to Life, the Universe and Everything is "42"
 - Douglas Adams, *Life, the Universe and Everything* (*Hitchhiker's Guide to the Galaxy* Trilogy)
 - "It Depends"
 - Universal legal answer